

# Post-Pandemic Monetary Policy

## and the Effective Lower Bound\*

Michael Woodford  
Columbia University

September 10, 2020

Since the global financial crisis of 2008, the effective lower bound on central-bank policy rates has come to constrain monetary policy choices with increasing frequency, both in the US and elsewhere. This raises a question about how chronically the problem of a binding lower bound may be expected to arise from now on. And given such worries, many central banks are asking to what extent this makes it appropriate to adopt a substantially different monetary policy strategy than might be possible in a higher interest-rate environment.

Much of the discussion of this challenge has urged that central banks simply try harder to make further reductions in real interest rates possible — adopting new targets, new tools, or institutional changes in order to facilitate this. For example, there has been greater openness to consideration of negative interest rates, even when this requires less uniformity of the short-run interest rates faced by different parties than under past policies; and calls for the abolition of cash in order to make more deeply negative interest rates feasible. Some propose that central banks should raise their long-run inflation targets, so that there would be more room to lower real rates, despite the floor on nominal rates. And many central banks have been much more active in using their balance sheets to reduce spreads between longer rates and the policy rate, so as to reduce long rates even if they cannot further lower the policy rate.

But another possible response would be to move away from sole reliance on interest-rate cuts as the way in which stabilization policy responds to recessionary shocks. In particular, though this is not a matter for central banks to decide on their own, I believe that we would do well to make more use of fiscal transfers as a tool of stabilization policy than was common under the policy frameworks adopted during the period of the “Great Moderation.”

---

\*Presented at the Federal Reserve Bank of Kansas City Symposium “Navigating the Decade Ahead: Implications for Monetary Policy,” August 28, 2020. Thanks to Lucrezia Reichlin, Argia Sbordone and Harald Uhlig for comments, and Yeji Sung for research assistance.

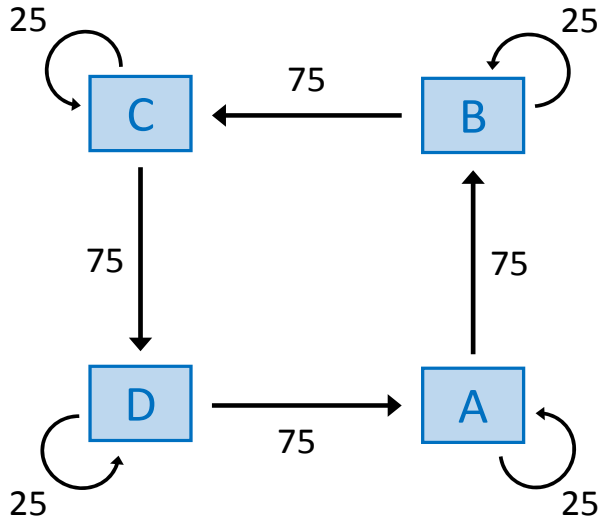

Figure 1: Example of a balanced circular flow of payments, in the absence of any pandemic shock.

My reasons for this suggestion go beyond the familiar argument that fiscal stimulus may be needed (as a last resort) if further interest-rate cuts are no longer possible. Many discussions presume that interest-rate cuts and fiscal stimulus are essentially two different ways of achieving the same effect (namely, increasing aggregate demand); hence fiscal policy need not be used for stabilization purposes when interest-rate policy is available to do the job, but should be considered if interest-rate policy is constrained by the effective lower bound. However, sometimes interest-rate policy fails to provide adequate stimulus, not because real interest rates have not been reduced enough, but because interest-rate policy is the wrong tool, given the fundamental nature of the economic problem.<sup>1</sup> The shock to the US economy from the COVID-19 pandemic provides a textbook example of such a case.

The orthodoxy that had developed prior to the global financial crisis — according to which interest-rate policy was the sole important tool of stabilization policy, and fiscal policy should not be set on the basis of cyclical considerations at all — was defensible under a particular view about the shocks to which stabilization policy would need to respond. This is the case in which both supply and demand shocks are expected to affect all sectors to a sufficiently similar extent to make a purely aggregative (one-sector) model of business fluctuations and of the effects of stabilization policy adequate. A crucial consequence of this assumption is that neither variations in the overall level of economic activity (efficient or otherwise) nor variations in the level of real interest rates required to keep aggregate demand in line with aggregate supply should pose any problem to the maintenance of a balanced circular flow of payments.

Figure 1 illustrates schematically what I mean by a balanced circular flow. The diagram depicts an economy made up of four sectors (A, B, C, D), assumed for simplicity to be equal in size. Units in each sector specialize in producing a particular kind of goods or services, but

<sup>1</sup>The argument sketched below is presented in more detail in Woodford (2020).

consume a greater variety of goods (though the sectoral composition of the goods consumed by different types of producers can also be different). In the case shown in the figure, it is assumed when all of the goods are offered for sale at the same price, units in any given sector wish to allocate 25 percent of their spending to goods produced by their own sector, and 75 percent to goods produced by the sector located counter-clockwise from their sector. (Thus 25 percent of total spending by units in sector A is on goods produced by sector A, and 75 percent is on goods produced by sector B. Sector B instead purchases from sectors B and C, and so on.) The arrows show the flow of payments for purchases, with numbers indicating the quantity paid over some time interval (in arbitrary units). While the flow of payments is shown by arrows in the figure, it should be understood that there is also a flow of goods and services, in the opposite direction of each arrow. (Goods produced by sector B are consumed in sectors B and A, and so on.) In the situation depicted in the diagram, the prevailing real interest rate on safe assets leads units in each sector to wish to spend an amount per period that is normalized as 100, if they can finance this level of spending. (This represents the outcome of an intertemporal trade-off, not depicted in the diagram.)

The important point to note about the figure is that the payment inflows for each unit exactly balance payment outflows (both are equal to 100). In such a situation, the economy can function smoothly, even if many units operate with only a low level of liquid assets, and find it difficult to borrow against future income, because enough income is always coming from current sales to cover desired outflows. As a result, no units ever face a borrowing constraint; each can consume the amount consistent with its intertemporal first-order condition (here assumed to equal 100). This equilibrium outcome also represents the first-best optimal allocation of resources for this economy (both with regard to the quantities produced, and how these goods are distributed).

If the economy is subject to shocks to preferences or productivity, as long as these shocks affect costs of production or utility from consumption in a similar way, the circular flow will continue to be balanced (albeit with payments flows that are either all smaller or all larger than the ones shown). In this case what needs to be done to ensure an efficient pattern of activity, despite the existence of sticky wages or prices, is simply to bring about a uniform increase or decrease in desired spending, across all sectors. And because borrowing constraints will not bind in any sector, adjusting the interest rate on riskless assets should be an effective means of simultaneously regulating demand in a uniform way across all sectors, as needed to ensure efficiency. Fiscal transfers will be unnecessary, and indeed — in a rational-expectations model with long-lived decision makers — they should be ineffective, given that borrowing constraints never bind.

But the situation can be quite different if there are disturbances with a significant asymmetry in their impact. Consider the effect of a disturbance like the lockdown in response to the COVID-19 pandemic, requiring many (but not nearly all) activities to be temporarily suspended for public health reasons. Suppose that in our example, one of the sectors (let us say sector A), can no longer produce and/or deliver the service that it previously supplied, for the duration of the lockdown; but that neither the cost of production nor utility from consumption of any other good is affected. Given this, the efficient allocation of resources during the period of the public health emergency is instead the one shown in Figure 2. In this figure, the arrows previously pointing to sector A are deleted (these correspond to service flows that are no longer possible); but all other arrows remain the same as in Figure 1,

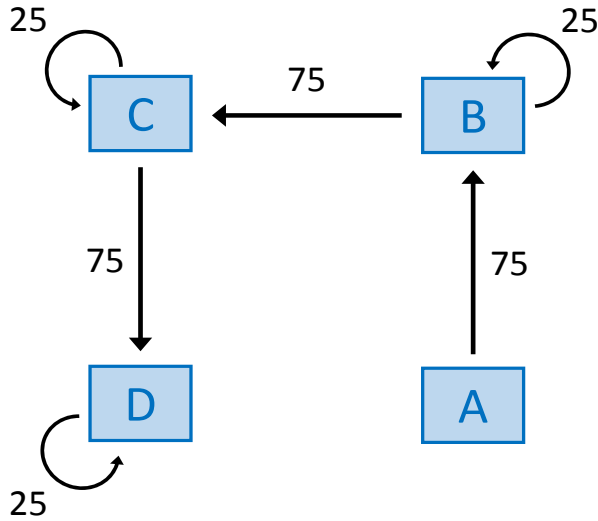

Figure 2: The efficient allocation of resources during the lockdown period, in the case of a pandemic shock that requires suspension of the production and consumption of the services supplied by sector A.

as these continue to represent goods and service flows for which the utility of consumption justifies the disutility involved in supplying these items.<sup>2</sup> (In Figure 2, we are really interested only in the flow of goods and services, rather than with the question of who pays for them; but we continue to use the same arrows as in Figure 1 to represent the direction and magnitude of these flows.)

The problem with this is that — assuming that we continue to value all goods at the same prices as before (predetermined prices, set before it was known that the pandemic would occur<sup>3</sup>), so that the required payment flows are the ones indicated by the numbers in Figure 2 — we no longer have a balanced flow of payments. The efficient pattern of production and consumption requires sector A to continue to consume, though units in sector A receive no income; sector D, on the other hand, is deprived of opportunities to spend on many of the things that would ordinarily interest it, but (under the efficient allocation) would continue to earn the same income as previously.

It follows that the efficient pattern of activity would not be able to be maintained for long, before units in sector A will have run down their liquid asset balances, and cease to be able to spend. But once this occurs, units in sector B will no longer receive income from sales

<sup>2</sup>The conclusion that it is efficient for all of these quantities to remain unchanged depends on an assumption of additive separability of the effects on utility of consumption or supply of different goods, as discussed further in Woodford (2020); the calculations would be more complex in the case of preference or production-side complementarities of the kind discussed by Guerrieri *et al.* (2020).

<sup>3</sup>This assumption simplifies the analysis, but sticky prices are not essential to the logic by which a collapse of effective demand results from disruption of the circular flow of payments. If we assumed completely flexible wages and prices, the collapse of economic activity would not be as severe as the one shown in Figure 3 below, but economic activity would still be much less than in the efficient pattern shown in Figure 2; and interest-rate cuts will still not be able to restore efficiency.

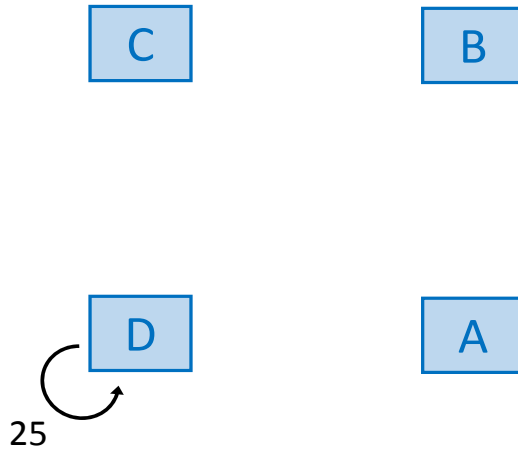

Figure 3: The equilibrium pattern of economic activity during the lockdown period, in the absence of any fiscal or monetary policy response.

to sector A; they will then not be able to maintain their desired level of spending without running down their liquid asset balances as well, and once these have been exhausted, the only possible level of spending by units in sector B (who will receive income equal to only 25 percent of their sector’s spending) will be zero. Once this occurs, units in sector C will no longer receive income from sales to units in sector B, and so on.

The equilibrium eventually reached (and fairly quickly, in the absence of any policy intervention, if the initial levels of liquid asset balances were low) will be the one shown in Figure 3. Units in sectors A, B, and C are all unable to spend at the level consistent with their intertemporal first-order conditions, because of binding borrowing constraints. Liquid assets are held only by units in sector D, which are accordingly not borrowing-constrained; these units spend on sector-D goods at the level implied by their intertemporal first-order condition, which (as in Figure 1) is assumed to be 25, but are not able to spend on sector A services owing to the lockdown.

Thus in the absence of any policy response, the disruption of the circular flow of payments results in a collapse of what Keynes (1936) calls “effective demand.”<sup>4</sup> This can bring about a much more severe reduction of economic activity than is efficient.<sup>5</sup> Note that the situation is one in which it is actually efficient for an abrupt and rather severe reduction of GDP to occur (GDP is 25 percent smaller in Figure 2 than in Figure 1); but the disappearance of many units’ normal income flows can lead to a much more severe, and highly inefficient reduction of activity on top of that (GDP has instead fallen by nearly 94 percent in the admittedly extreme example shown in Figure 3).

What if monetary policy instead responds to the fact that economic activity is far below potential, by slashing interest rates? In our model, because we assume some temporary

<sup>4</sup>See also Leijonhufvud (1973) for an important clarification of this concept.

<sup>5</sup>This is also a main point of the important discussion by Guerrieri *et al.* (2020).

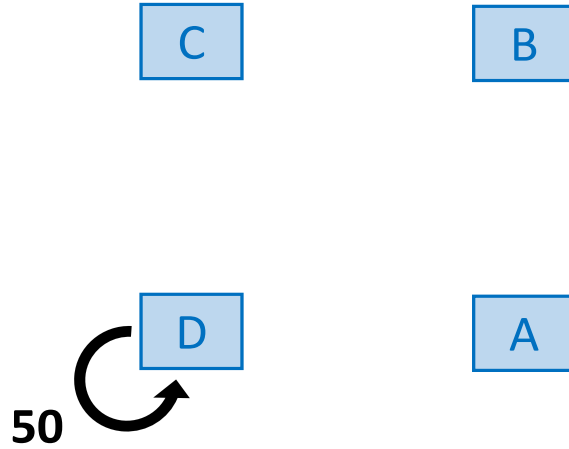

Figure 4: The effect of cutting the riskless rate of return in response to the pandemic shock.

stickiness of prices, monetary policy can reduce the real rate of return and stimulate real expenditure. But the only thing that a reduction in the rate of return on assets can do is to create an expansion of the kind shown in Figure 4. Because units in sector D are not borrowing-constrained, the amount of their spending on sector-D goods is determined by an intertemporal first-order condition, and a lower real rate of return increases desired spending on these goods during the lockdown. However, units in sector D continue to spend only on sector-D goods (under our assumption about preferences), given that they are unable to purchase sector-A services. Units in sectors A, B, and C continue to be borrowing-constrained; the fact that the rate of return that they would receive on liquid assets has fallen does not relax their financing constraints, and they continue to be unable to spend.

In the case shown in Figure 4, we have supposed that a very dramatic reduction in real interest rates is possible, so that the level of spending consistent with units' intertemporal first-order conditions is doubled. In practice, the effective lower bound would likely prevent interest rates from being cut to anything like this extent, and in that case the increase in spending would not be as great. But it would be a mistake to conclude that the effective lower bound is what prevents monetary policy from achieving a stronger recovery. Even if the constraint of the effective lower bound were to be eliminated (by abolishing cash, and so on), it would still only be possible for interest-rate reductions to increase demand in the particular way illustrated in Figure 4.

In this example, an interest-rate cut doesn't increase any of the kinds of spending that are inefficiently low in Figure 3 (the spending by units in sectors A, B, or C); it only increases a particular type of spending (spending by sector-D units on sector-D goods), that was *already* at its socially-efficient level in the absence of the interest-rate cut, and thus leads to excessive use of resources in this particular way. Even though economic activity is inefficiently low in the situation depicted in Figure 3, the increased activity shown in Figure 4 does not necessarily increase welfare. Even in a less extreme example, when stimulating demand in non-borrowing-constrained sectors has some spillovers to borrowing-constrained sectors,

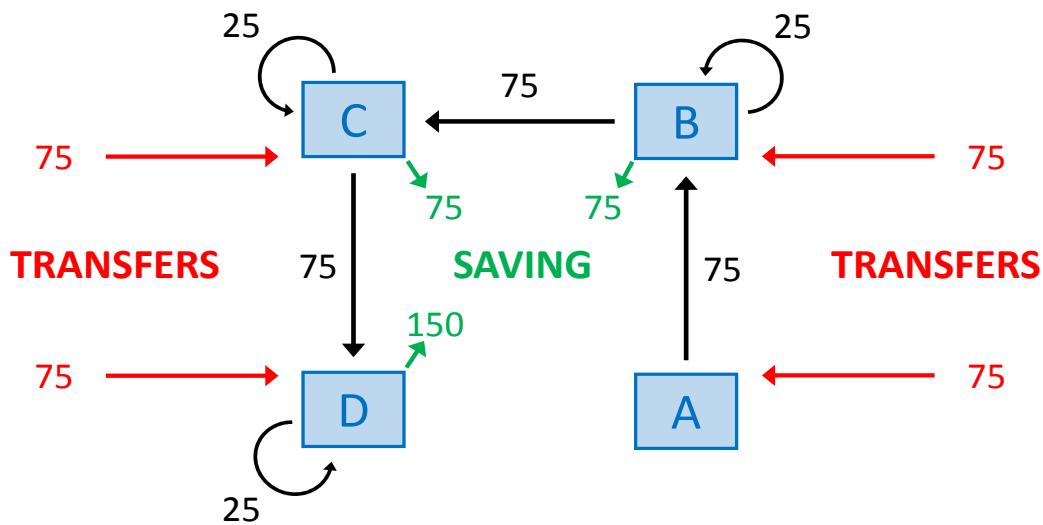

Figure 5: The effects of uniform transfers to all sectors, in the amount of the sector A income that needs to be replaced.

the benefits of increased income in the latter sectors are at least partially offset by the stimulus to increased spending of relatively inefficient kinds (a consequence of reducing the real interest rate below the Wicksellian “natural rate of interest,” which here is not reduced by the pandemic shock).

When an effective demand collapse of the kind shown in Figure 3 occurs, there is instead a strong case for the use of fiscal transfers as a tool of stabilization policy. First of all, these matter (even if everyone has rational expectations) in a situation where many economic units are borrowing-constrained, assuming that at least part of the transfers go to borrowing-constrained units. Moreover, such transfers don’t just increase aggregate demand (something that interest-rate cuts can also achieve); they can increase the specific kinds of spending that are needed to achieve a more efficient allocation of resources. And they can do this even without having to be too precisely targeted.

Figure 5 provides an example. In this figure, it is assumed that the government simply sends checks to everyone in the economy, regardless of the way in which they have been impacted by the pandemic (an assumption that greatly increases the administrative simplicity of the policy). In the case shown, each unit receives a transfer of size 75 (the amount of additional income that units in sector A require, in order to be able to finance the spending shown in Figure 2). Monetary policy is assumed to be unchanged (interest rates remain at the same level as in Figure 1). In the resulting equilibrium, borrowing constraints no longer bind for any sector, and units in each sector choose (and are able to finance) the same level of spending on goods produced by sectors other than sector A as they choose in Figure 1. Excess funds beyond those needed to finance the level of spending consistent with the intertemporal first-order condition are saved. The desired saving that results in this way is exactly equal, in its aggregate value, to the value of the public debt that must be issued to finance the transfers (a total value of 300).

The resulting flows of goods and services (the flows that represent the counterpart of the

payments indicated by black arrows running from one box to another) are the same as in Figure 2; thus the first-best optimal allocation of resources is achieved as an equilibrium of the decentralized economy. Unlike what we found in the case of aggregate demand stimulus through interest-rate cuts, sufficiently large fiscal transfers not only increase welfare, but can achieve the first-best outcome. Nor does this require that the size or distribution of the transfers be carefully calibrated. In fact, in order for the equilibrium allocation during the lockdown to be the one shown, it only matters that the transfer to each of the units in sector A be 75 or larger; the relative size of the transfers received by other units is irrelevant (as these transfers are in any event saved).

It is also worth noting that in this example, achieving the first-best outcome does not require any reduction of interest rates. In fact, achieving the first-best outcome requires that interest rates *not* be cut, as any reduction in the real interest rate will stimulate inefficient uses of resources.

This doesn't mean that central banks have no role to play in responding to a crisis like the COVID-19 pandemic. To the extent that the social insurance provided by fiscal policy is inadequate — or there are doubts about whether it will come on line fast enough — capital markets and financial markets may come under strain, as people anticipate a potential wave of insolvencies due to the lockdown. If such strains in financial markets develop, it is altogether appropriate for the central bank to step in, as indeed the Fed did early in the COVID-19 crisis, to ensure the continued efficient functioning of the financial system. And given the role of borrowing constraints in the dynamics of the collapse of effective demand, emergency extensions of credit, in which the central bank may well play a crucial facilitating role (even though these are really fiscal policies), can also greatly benefit the economy. But neither of these types of interventions require a reduction in the rate of interest on safe assets; they instead involve keeping borrowing rates from rising too far above the rate of interest on safe assets.

To the extent that deep cuts in real interest rates are not really what is needed to deal with this kind of crisis, it follows that the existence of an effective lower bound on the central bank's policy rate may not really be what is keeping the economy from recovering more quickly. And this in turn means that there may be less to be gained from expedients such as an increase in the long-run inflation target, or the abolition of cash, than a focus on the problem of the lower bound constraint would suggest.



## References

- [1] Guerrieri, Veronica, Guido Lorenzoni, Ludwig Straub, and Iván Werning, “Macroeconomic Implications of COVID-19: Can Negative Supply Shocks Cause Demand Shortages?” NBER Working Paper no. 26918, April 2020.
- [2] Keynes, John Maynard, *The General Theory of Employment, Interest and Money*, London: MacMillan, 1936.
- [3] Leijonhufvud, Axel, “Effective Demand Failures,” *Swedish Journal of Economics* 75: 27-48 (1973).
- [4] Woodford, Michael, “Effective Demand Failures and the Limits of Monetary Stabilization Policy,” CEPR Discussion Paper no. 15211, August 2020.